

# Technology that builds confidence

**Strong Machines Case Study:**

**Safe crane operations with Tele Radio**

# THE CHALLENGE

When handling heavy loads with overhead cranes operating in tandem, every movement must be precise and synchronized. In industrial environments such as metalworking facilities, where safety and coordination are critical, even small errors can lead to serious damage or accidents.



Strong Machines needed a system that would ensure:

- Perfect coordination between overhead cranes.
- Maximum operator safety in harsh industrial conditions.
- Robust and reliable communication between operator and equipment — even from a distance

A wireless control system was essential to eliminate physical restrictions, reduce human error, and provide operators with full freedom of movement without compromising control precision.



Strong Machines is a Brazilian manufacturer specializing in heavy-duty load-handling systems.

Headquartered in Caxias do Sul/RS, the company delivers high-performance solutions for industrial applications across Brazil.

With years of experience and a strong focus on innovation, Strong Machines continuously invests in technologies that enhance safety, reliability, and usability.

The partnership with Tele Radio reflects their commitment to smart, safe solutions tailored to real-world industry needs.

# SOLUTION OVERVIEW

## Tele Radio's Tiger System

To ensure total synchronization between cranes, Strong Machines chose Tele Radio's Tiger system. The decision was based on several key factors:

### **Certified safety**

The system is equipped with a mushroom-type emergency stop (E-stop) and complies with PLd/SIL3 safety certifications. This ensures that even in the most critical scenarios, operations can be halted instantly—minimizing risks and keeping personnel and equipment safe.

### **Seamless CANopen integration**

The system automatically synchronizes controls, streamlining setup and ensuring smooth operation across connected components—ideal for complex vehicle recovery systems.



### **Proportional control**

The operator can finely adjust movement speeds based on how much pressure is applied. This allows for smooth, accurate operation.

### **Ease of use**

Ergonomic and durable transmitters designed for demanding industrial environments.

# THE SOLUTION IN ACTION

## How Tiger works in Tandem Crane operations

Tele Radio technology allows two cranes to operate in perfect synchronization using a single transmitter. This is made possible through the Tiger system, which enables secure communication between transmitters and the receivers on each crane.

In tandem mode, the operator controls both cranes simultaneously—ensuring they move forward, backward, or lift in perfect unison. This is essential when handling long, heavy, or delicate loads, helping avoid misalignment or uneven tension during transport.

The system configuration allows operators to switch between individual and synchronized control modes, adapting easily to different phases of the job. The diagram (not shown here) illustrates how the transmitter communicates with receivers and how functions are distributed to maintain safe and precise operations.

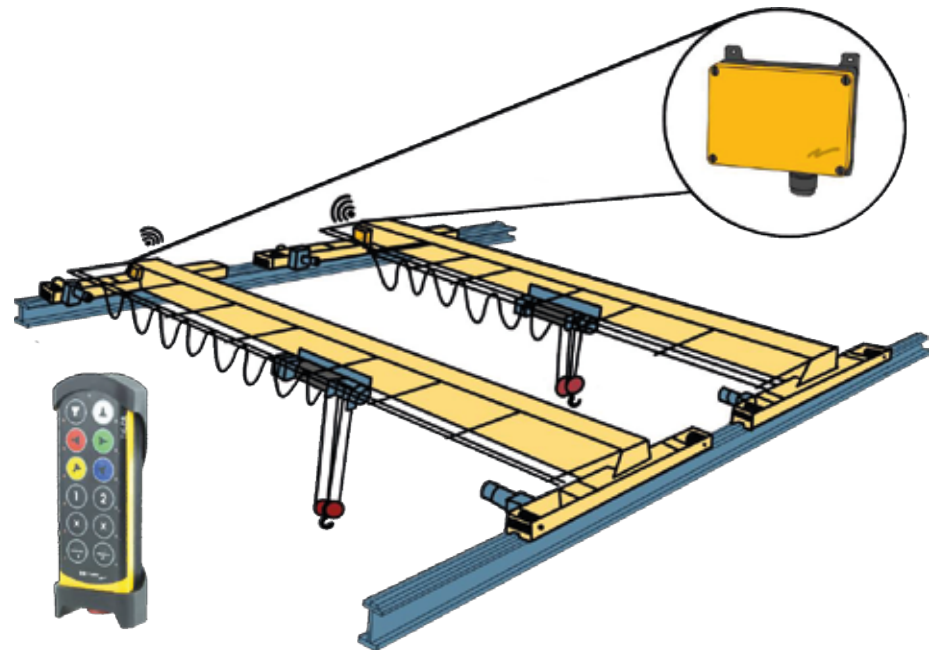

# COMPETITIVE ADVANTAGES

## Why Strong Machines chose Tele Radio



### Fast and simple installation

The system was implemented efficiently with minimal disruption—reducing installation time and avoiding extended downtime.



### Safety first

The Tiger system meets the highest safety standards, including SIL3, PLe, and CAT3, with reliable emergency stop functionality.

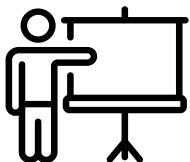

### Specialized training

Tele Radio Brazil provided on-site support and training, ensuring Strong Machines used the equipment safely and effectively.

### National stock

Having stock available in each country shortens lead times and ensures quick replacements or additional orders.

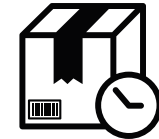

### A trusted partnership

With decades of experience in wireless remote control for industrial use, Tele Radio is recognized worldwide for the reliability of its products and technical support.





*“Tele Radio proved to be more than a supplier — they are a strategic partner.*

*They understood our challenges, supported us with training, and delivered a solution that fits our product perfectly.”*

— Markus Grallert, Director at Strong Machines

**Safe. Smart. Strong.**

 [www.tele-radio.com/us](http://www.tele-radio.com/us)

 [usa@teleradio.com](mailto:usa@teleradio.com)

 +1 (305)459 0763

 14895 NE 20th Ave North Miami FL 33181, United States